

# R22 BETA II



The two-seat R22 helicopter is a proven workhorse that has delivered exceptional performance in a variety of applications for over thirty years. The R22 has a two-bladed rotor system, T-bar cyclic and the latest in Robinson technology including crashworthy bladder fuel tanks.

A powder-coated steel tube structure provides a light yet rigid airframe while the aircraft's aerodynamic fuselage optimizes airspeed and fuel economy. The R22 is powered by Lycoming's proven O-360 engine that is derated to provide reserve power and better performance at high altitudes and in hot weather.

## OPTIONS

- Leather Seats in Tan, Charcoal or Gray
- Aspen Primary Flight Displays
- Garmin GTN 600 Series Touchscreen Navigators
- Garmin ADS-B Compliant Transponders
- Garmin GMA 350Hc Audio Panel
- Bose A20 Headsets with Bluetooth



Shown with left side controls removed, optional Aspen EFD 1000H PFD and Garmin GTN 625 in pilot-side-console



Shown with optional artificial horizon and digital clock

# R22 BETA II

## SPECIFICATIONS

Engine	Lycoming O-360, four cylinder, carbureted
Horsepower	Derated to 131 hp for takeoff and 124 continuous
Maximum Gross Weight	1370 lb (622 kg)
Approximate Empty Weight (including oil & std avionics)	880 lb (399 kg)
Standard Fuel (16.9 gal)	101 lb (46 kg)
Auxiliary Fuel (9.4 gal)	56 lb (25 kg)
Pilot, Passenger, and Baggage (with standard fuel)	389 lb (176 kg)
Max Airspeed (Vne)	102 kts (189 km/h)
Cruise Speed	up to 96 kts (178 km/h)
Maximum Range (no reserve)	approx 250 nm (460 km)
Hover Ceiling IGE at 1370 lb	9400 ft
Hover Ceiling OGE at 1300 lb	8000 ft
Maximum Operating Altitude	14,000 ft
Electrical System	14 volt

## DIMENSIONS

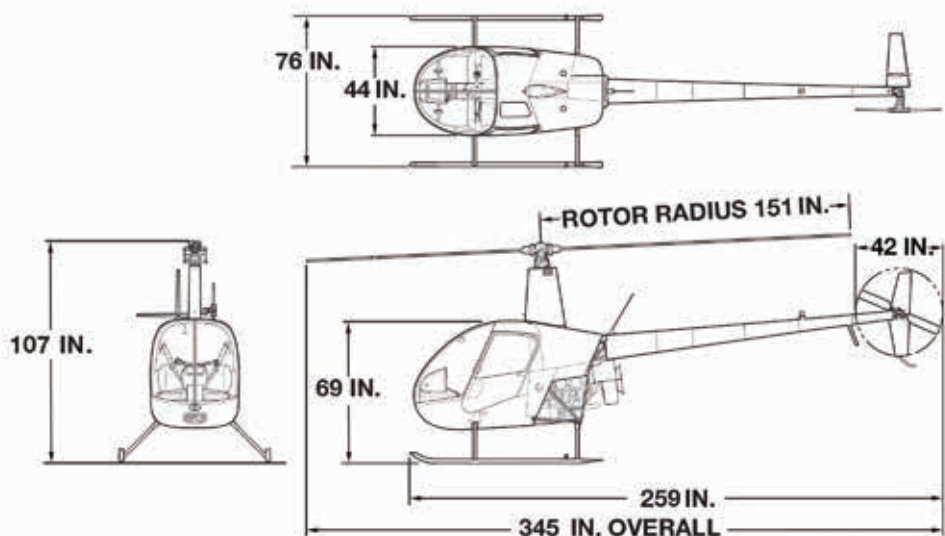

## STANDARD AVIONICS

- 6-hole instrument panel
- GTR 225B COM radio
- GTX 327 Mode C transponder

## STANDARD INSTRUMENTS

- Airspeed indicator
- Altimeter
- Rotor/engine dual tachometer
- Manifold pressure gage
- Vertical speed indicator
- Magnetic compass
- Cylinder head temperature gage
- Oil temperature and pressure gages
- Fuel gages
- Ammeter
- Carburetor temperature gage
- Digital OAT gage/voltmeter
- Hourmeter
- Quartz clock

## STANDARD EQUIPMENT

- RPM throttle governor
- Throttle correlator
- Carburetor heat assist
- Main and auxiliary crashworthy fuel bladder tanks
- Engine oil filter and quick drain
- Rotor brake
- Intercom switches
- Avionics master switch
- Tinted windows
- Fabric velour seats
- 3-point shoulder harnesses
- Door locks
- Engine muffler
- Sound damping headliner
- Underseat storage
- Belly hardpoint
- LED anti-collision and navigation lights
- Dual landing lights
- LED panel and map lights
- Tow cart adapter
- Ground handling wheels
- Rotor blade tie downs
- Windshield cover
- Travel bag

## ROBINSON HELICOPTER COMPANY

2901 Airport Drive • Torrance, CA • 90505 • USA  
Phone: 310-539-0508 • Fax: 310-539-5198  
[www.robinsonheli.com](http://www.robinsonheli.com)